



TMdrive[®]-XL85 Product Application Guide

Medium Voltage 5-Level Drive

metals

cranes

mining

testing

oil & gas

solar inverters

utilities

cement

TMdrive-XL85 High-Power Drive

Electric Compressor Drive Application

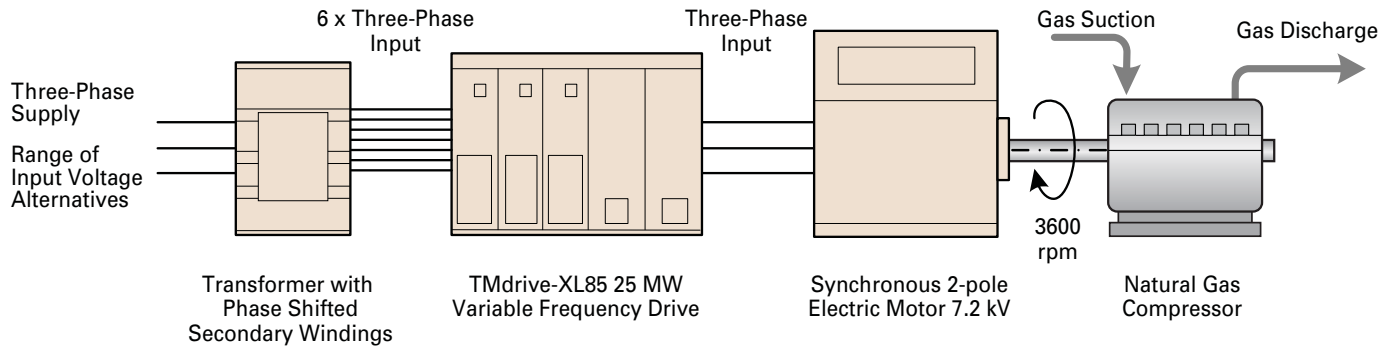







The TMdrive-XL85 variable frequency drive is designed to meet Oil & Gas industry needs for:

- High power
- High reliability
- Output frequency range for direct compressor drive
- Reduced energy consumption

Power Levels using parallel banks of TMdrive-XL85:

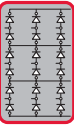
- One-Bank – 25 MW
- Two-Bank – 50 MW
- Three-Bank – 75 MW
- Four-Bank – 100 MW

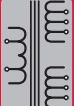
Synchronous or induction motors can be driven.

Design Feature	Customer Benefit
 <ul style="list-style-type: none"> • Conservative design using 6000 V–6000 A Gate Commutated Turn-off Thyristors (GCTs) 	<ul style="list-style-type: none"> • Highly reliable operation, expected 20 year drive MTBF
 <ul style="list-style-type: none"> • High energy efficiency of approximately 98.6% 	<ul style="list-style-type: none"> • Considerable energy savings
 <ul style="list-style-type: none"> • Diode rectifier ensures power factor greater than 95% in the speed control range 	<ul style="list-style-type: none"> • Capacitors not required for power factor
 <ul style="list-style-type: none"> • 36-pulse converter rectifier by using phase shifted transformer 	<ul style="list-style-type: none"> • No harmonic filter required to provide lower harmonic distortion levels than IEEE-519-1992 guidelines
 <ul style="list-style-type: none"> • Five level drive output waveform to the motor 	<ul style="list-style-type: none"> • Smooth output voltage, motor friendly wave form
 <ul style="list-style-type: none"> • Externally mounted input isolation transformer 	<ul style="list-style-type: none"> • Less power loss in drive room • Less total space required • Simplifies design and installation
 <ul style="list-style-type: none"> • Up to 7.2 kV direct drive voltage output level 	<ul style="list-style-type: none"> • No output transformer required, saving cost, mounting space, and energy

Designed for Large Compressors



Liquefied Natural Gas Plants

LNG plants have large refrigeration compressors driven by high power turbines or electric motors of over 20 MW size and with speeds of over 3,000 rpm. The TMdrive-XL85 combined with TMEIC's two-pole synchronous motor is specially designed for this application.



Gas Pipelines

Large compressors on gas pipelines require high power and speed – usually provided by gas turbines. Replacing the turbine with an electric motor and TMdrive-XL85 drive provides higher reliability, uptime, and efficiency, and in addition, NO_x and noise are eliminated.



Chemical Plants and Refineries

Large compressors requiring over 20,000 hp are found in refineries and chemical plants. The TMdrive-XL85 drive and electric motor offer high-reliability, high-availability, lower pollution, and lower noise level for these applications.



Steel Plants

Steel plant blast furnaces use large air flows requiring high power levels, which can be supplied by the TMdrive-XL85 drive.

A Look Inside

Advanced Technology for High Power

- World's largest Gate Commutated Thyristor (GCT) rated for 6000 A and 6kV, provides high-speed switching
- Water-cooling technology for the power bridge reduces drive footprint, saving valuable space
- Modular design power bridge minimizes time for any maintenance activities

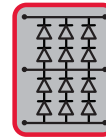

**Diode Rectifier
DC Source Module**

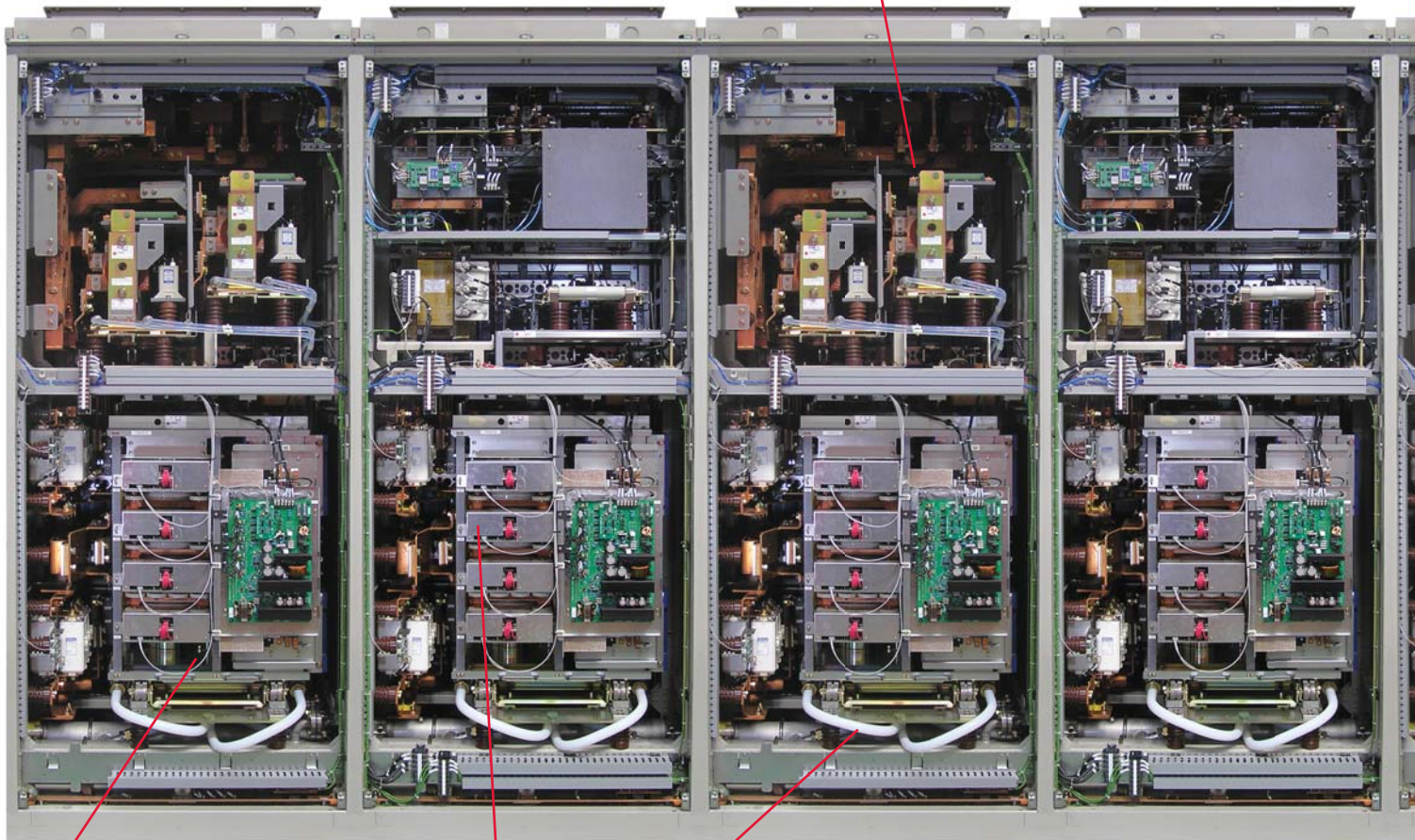

U-Phase

V-Phase



GCT Stack



**Water Cooling Tubes
for Cell Stack Assemblies**

**Motor and
Transformer
Connectors**

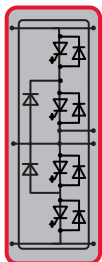

GCT Cell Stack Assembly

The drive has a total of six GCT cell stack modules in the inverter. The modular draw-out assembly includes:

- Four GCT power semiconductors
- Four fast recovery diodes
- Two neutral-point clamp diodes
- Water cooling piping with quick disconnect fittings
- GCT gate driver circuit board

Top View



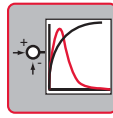

Main Control Panel

The primary control board provides:

- Volt/Hertz control
- Sequencing
- Diagnostic data gathering
- Optional LAN interface board

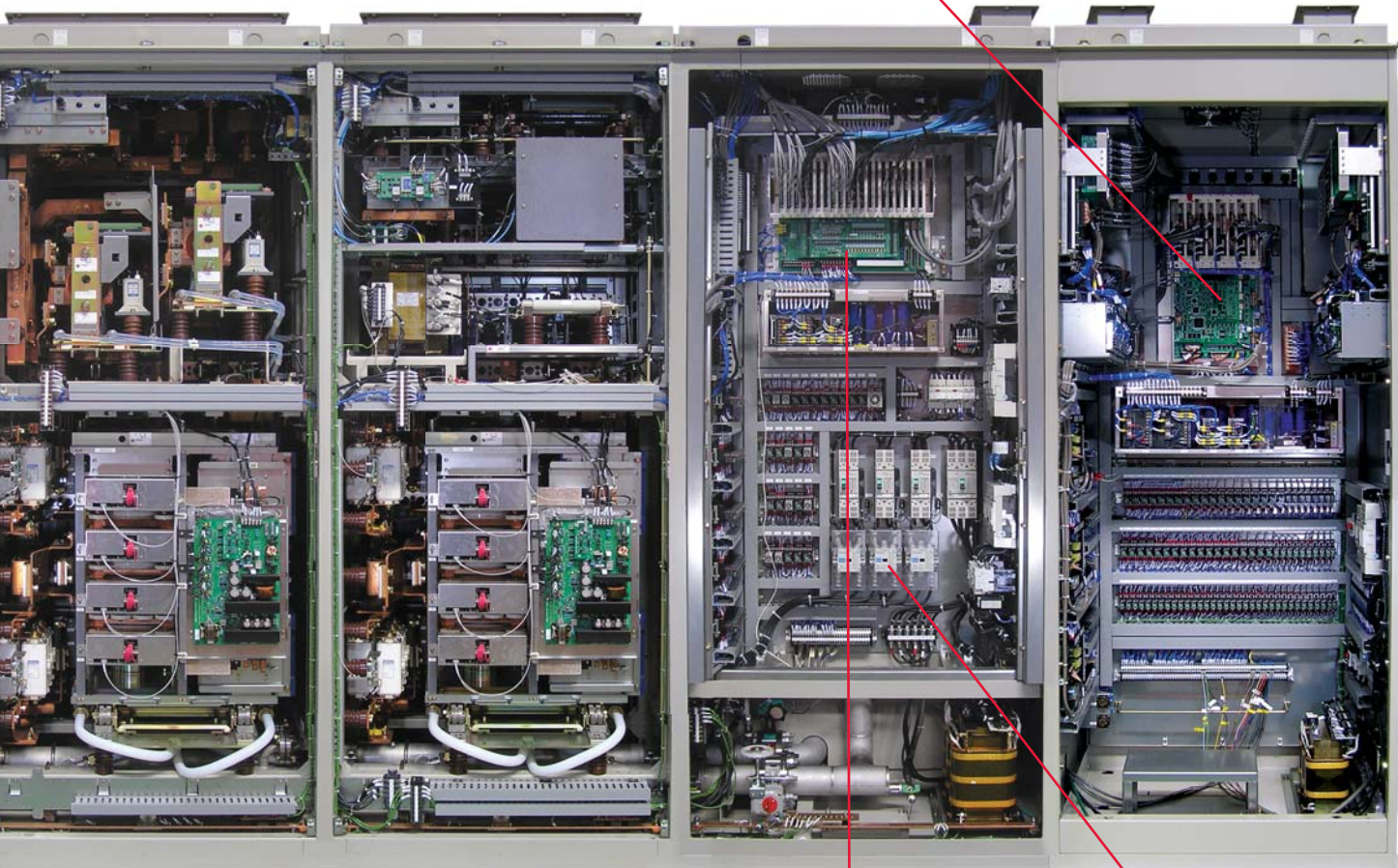

W-Phase



Gate Drive Panel

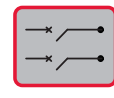

Control Power Distribution

Cooling Fans

Back View

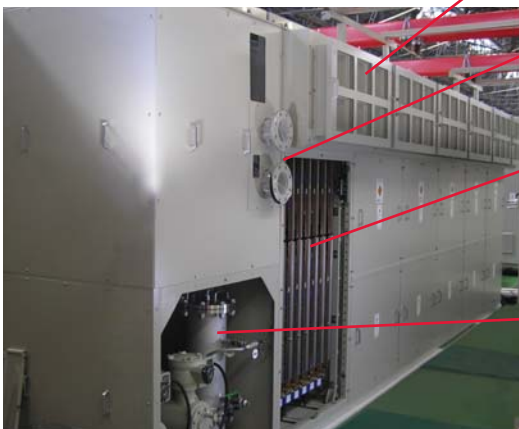

Customer Industrial Water Connections



Main Capacitors

Film-type dc capacitors are used to provide long life under all service conditions and duty cycles

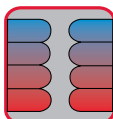

Cooling Water System

For details of pumps, heat exchanges and de-ionizer see page 12

TMdrive-XL85 Architecture

TMdrive-XL85 high-power level architecture consists of:

- Two diode rectifier modules per phase
- Two inverter half-modules per phase
- Phase shifted transformer externally mounted

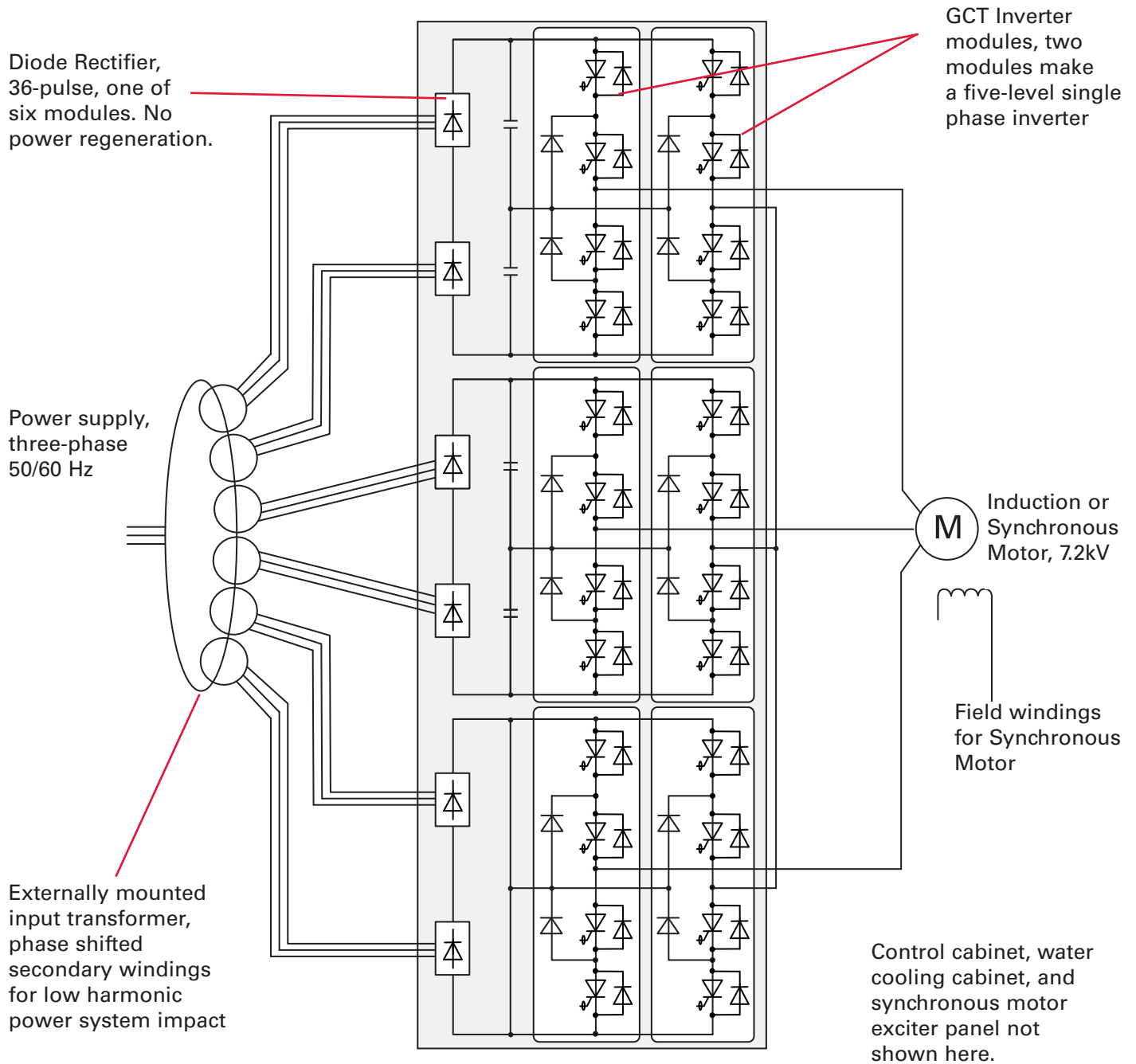

GCT Inverter Module

This inverter half-module has four Gate Commutated turn-off thyristors rated for 6,000 amps and 6,000 volts. Two modules make one inverter phase assembly.

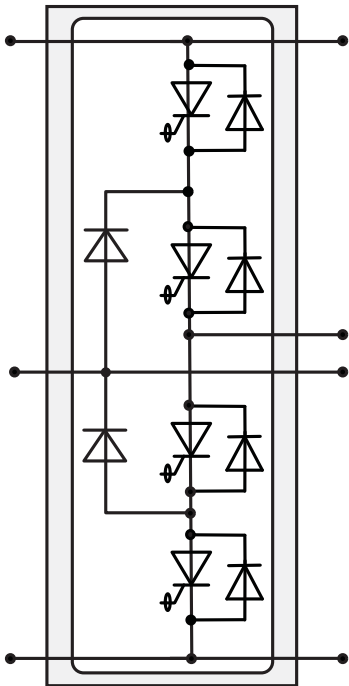

GCT Assembly showing firing circuits and control board, four per half-module

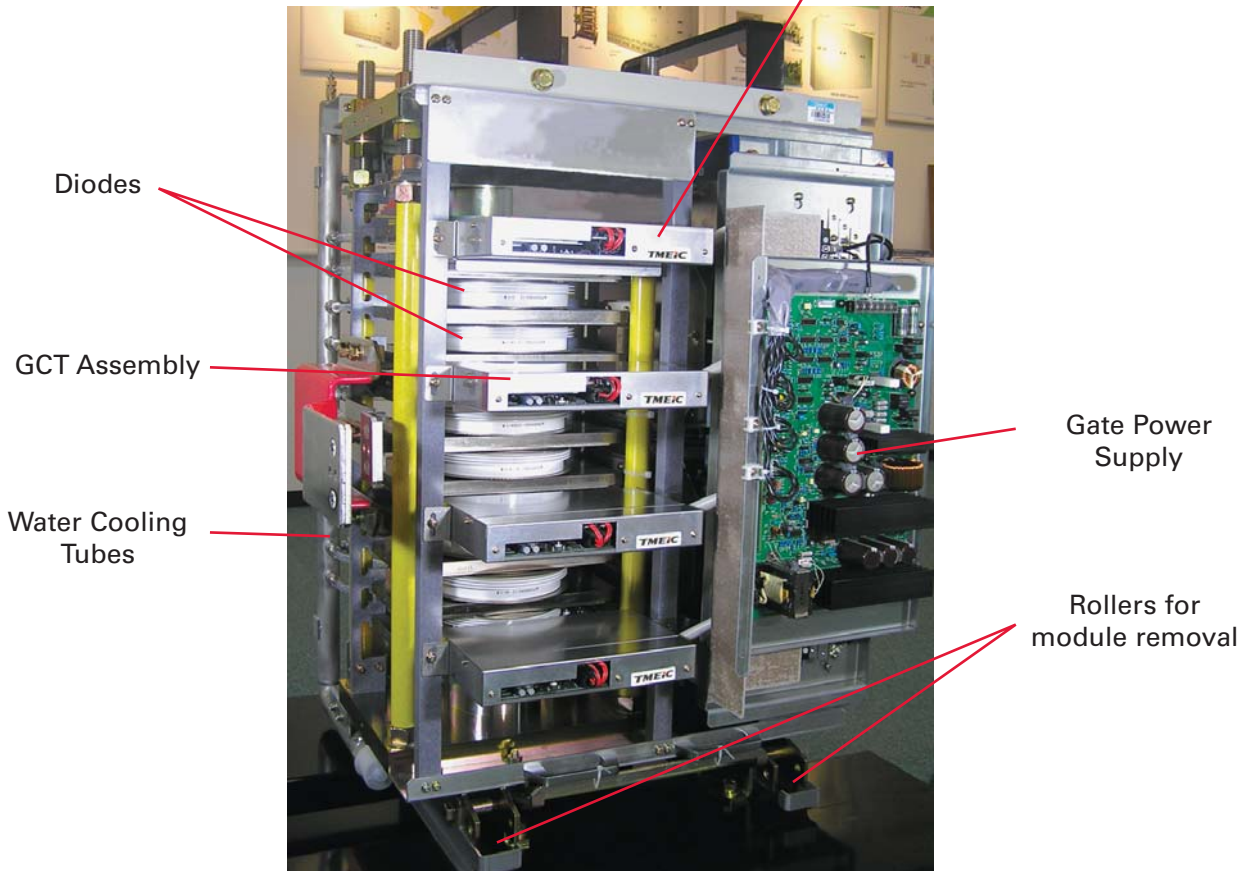

Drive Panel Line Up



TMdrive-XL85 Single Bank Cabinet Line-Up

Top View

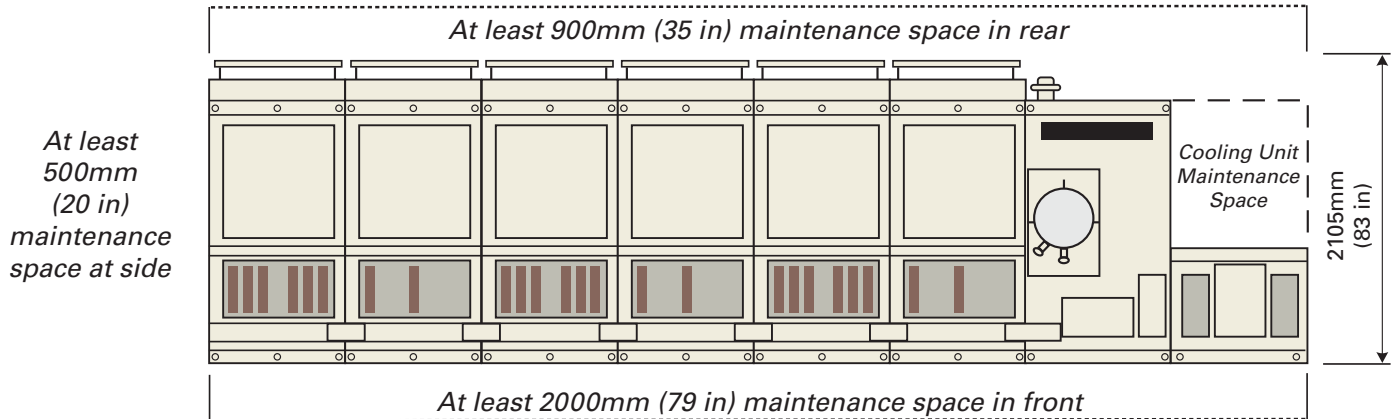

Front View

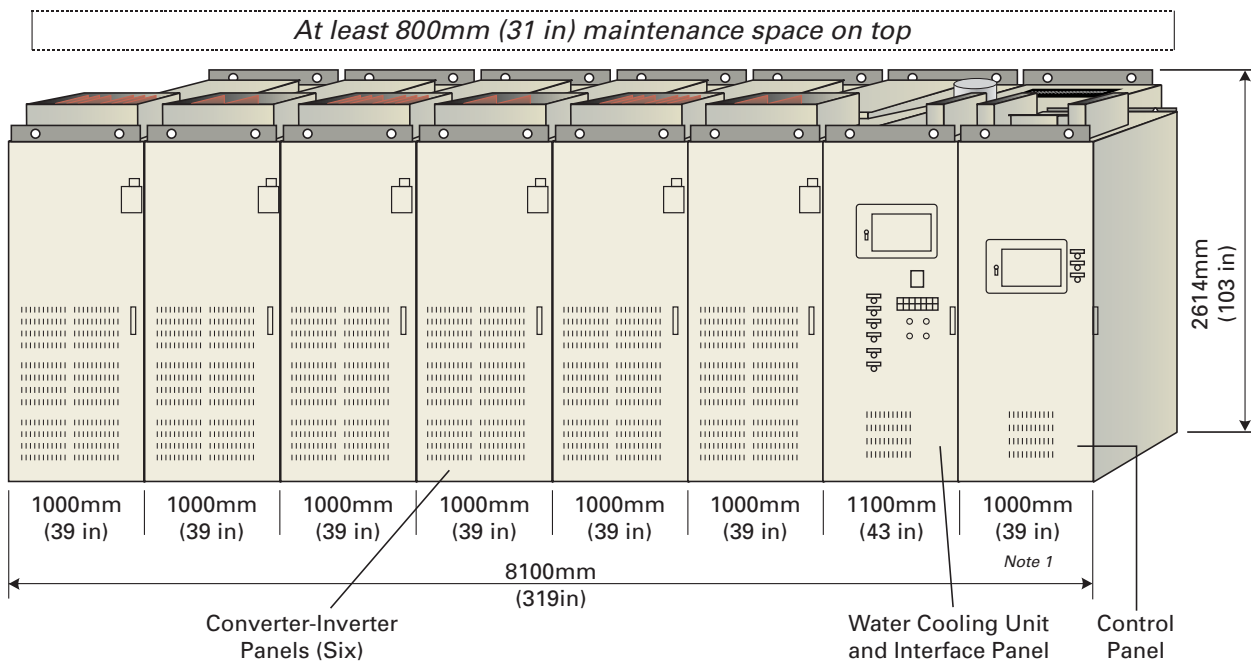

Drive Specifications

	Voltage kV	Power MVA	Motor Current A	Height mm (in)	Width mm (in)	Depth mm (in)	Weight kg (lbs)
Single Bank Drive	6.6 to 7.2	30	2400	2614 (103)	8100 (319)	2105 (83)	21000 (46200)

Dimensions shown are for a 30 MVA (30,000 kVA) single bank drive.
 Power outputs up to 120 MVA will use multiple banks similar to above.
 Weight is for line-up with no water, and does not include exciter panel.

Note 1: Compact type control panel (W800mm) is available for a single-bank of TMdrive-XL85

High-Power Levels Using Parallel Banks

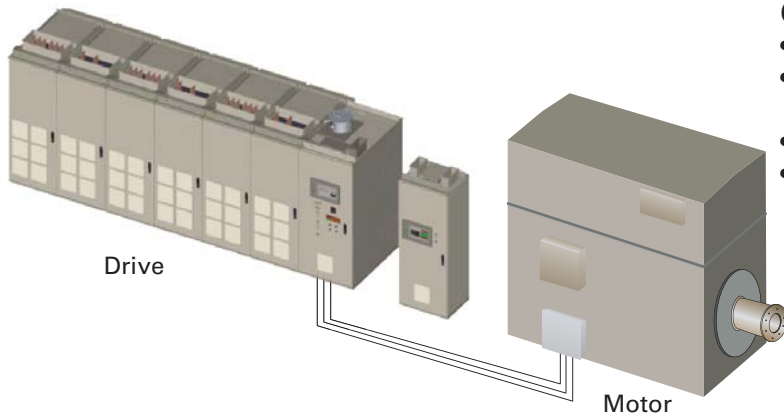

One-Bank XL85 Variable Frequency Drive

- Power level 25 MW
- One cooling water panel with included interface panel
- Synchronous motor 7.2kV
- Drive input transformers not shown

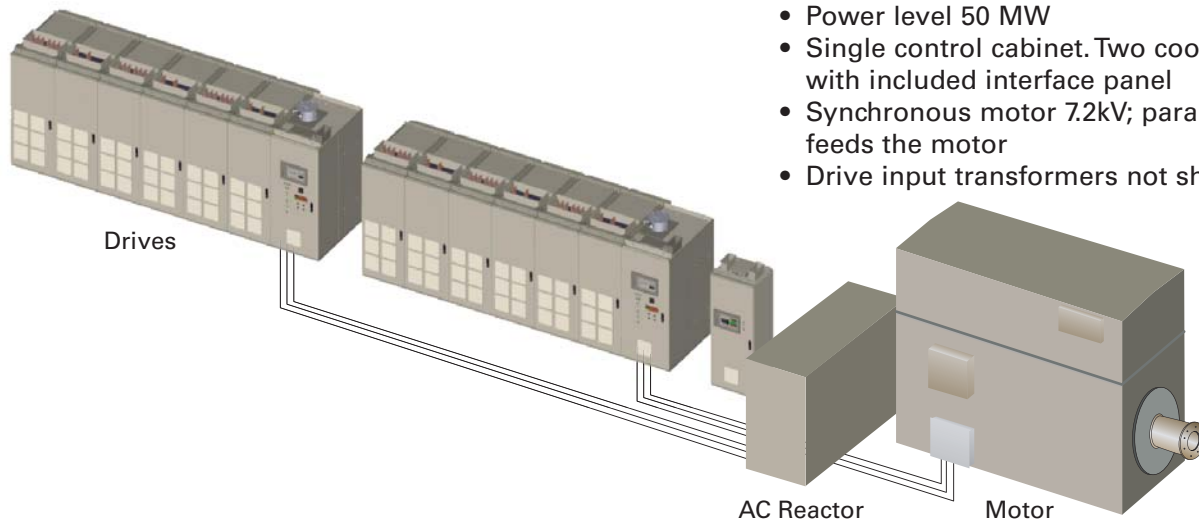

Two-Bank XL85 Variable Frequency Drive

- Power level 50 MW
- Single control cabinet. Two cooling water panels with included interface panel
- Synchronous motor 7.2kV; paralleling reactor feeds the motor
- Drive input transformers not shown

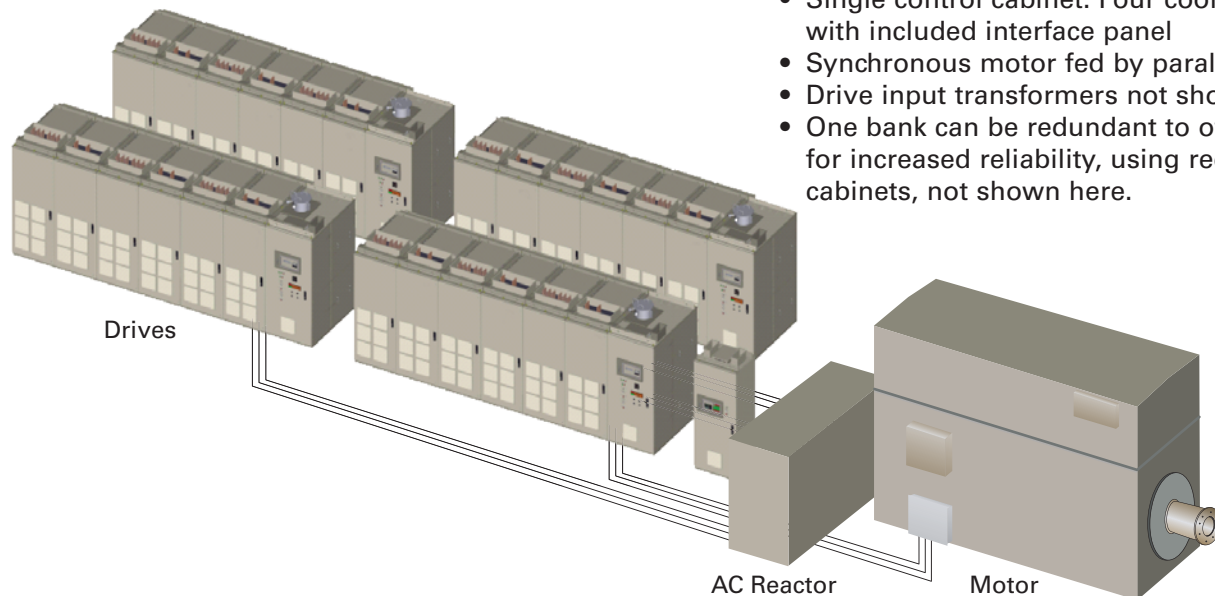

Four-Bank XL85 Variable Frequency Drive

- Power level 100 MW
- Single control cabinet. Four cooling water panels with included interface panel
- Synchronous motor fed by paralleling reactor
- Drive input transformers not shown
- One bank can be redundant to other three banks for increased reliability, using redundant control cabinets, not shown here.

Features of the TMdrive-XL85

A Clean Wave Inverter

Using the multiple winding input transformer, the TMdrive-XL85 has 36-pulse rectification, which reduces the harmonic voltage distortion on the power source and protects the other equipment in the plant. The harmonic current content measured in an actual load test is compared with IEEE-519 in the chart opposite, showing it more than meets the standard.

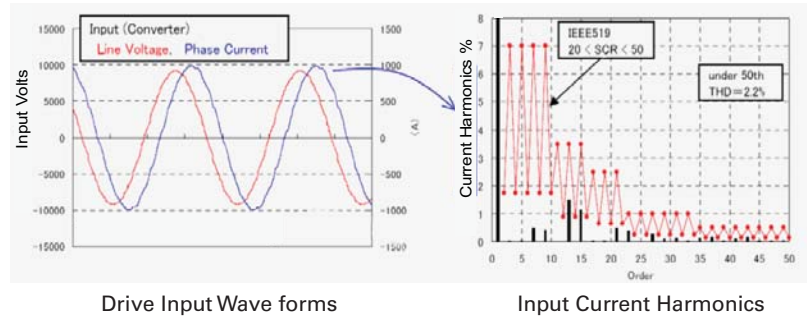

Drive Input Wave forms

Input Current Harmonics

A Clean Output Wave

As a result of the five-level PWM control, the output current waveform is close to a sine wave, and the heat loss in the windings caused by harmonics is negligible. In addition, harmonic currents in the motor are minimized so there is very little torque ripple on the output shaft.

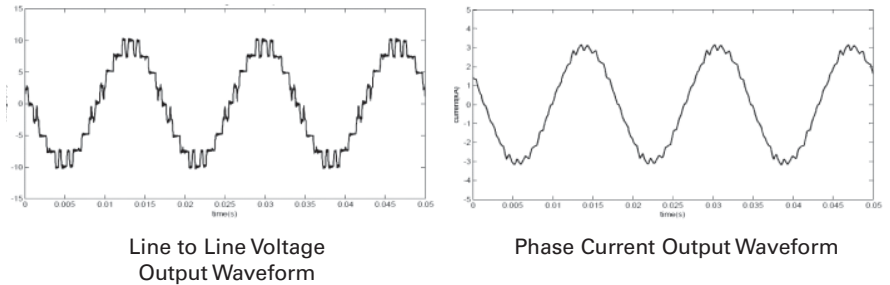

Line to Line Voltage Output Waveform

Phase Current Output Waveform

A Higher Efficiency than Conventional Drives

Actual factory load tests show the drive efficiency is approximately 98.6% (design value). This high efficiency is a result of:

- A smaller number of switching semiconductors by using 6kV GCTs
- Lower switching frequencies using multilevel PWM control reduce the switching loss of each GCT
- Direct connection of 7kV motor without an output transformer

A High Input Power Factor

As a result of the diode bridge rectifier, the input power factor is above 95% over the entire normal operating speed range, even when driving a multiple-pole induction motor of low power factor. With this high power factor, no power factor correction capacitor is required.



Environmental

Operating Air Temperature	0 to 40°C (32 to 104°F) at rated load 0 to 45°C (32 to 113°F) with derating
Storage Temperature	-25 to 70°C (-13 to 158°F)
Humidity	5 to 95% relative humidity Non-condensing
Altitude	Up to 1000 m Up to 3000 m with derating
Vibration	10-50 Hz, <0.5 G IEC 61800-4 5.1.22
Industrial Water Temperature	0°C - 40°C at inlet 0°C - 45°C at inlet with derate



Motor Control

Volt/Hertz Control

- Frequency control accuracy:
+/- 0.5% (analog setting)
- Frequency setting resolution:
1/1000 or more (analog setting)
- Normal torque:
Below 50% frequency, squaring load
Below 50% frequency, 100% load

Pulse Width Modulation Control

- 0-25% speed, Asynchronous PWM
 - 25-50% speed, Synchronous PWM
 - 50-100% speed, Fixed Pulse Width
- Variable Switching frequency up to 600 Hz



Power Input/Output

Input Voltage	3 x 2 x 2105 V ±10% 50/60 Hz ± 2%
Input Harmonics	IEEE 519 compliant without filters
Power (for Pre-charge, Gate Power, Cooling Fan, IRU, Relay)	220 V (50/60 Hz) 3-phase without transformer 200 V (50 Hz) 380/400/440/460/480/575/690 V using transformer
Cooling Pumps	380 V-50 Hz 400 V-50/60 Hz 440 V-60 Hz 200/220/460/480/575/690V-60 Hz
Displacement Power Factor	.95
Output Voltage	7200 Vac
Output Current	2400 A rms
Output Current Derating	Ambiant Temp. Derating 40°C 1.00 45°C 0.94
Output Frequency	50-60 Hz, 50-200 Hz with derate above 100 Hz
Output Chopping Frequency	600 Hz (max)
Efficiency	98.6%



Standard Connection

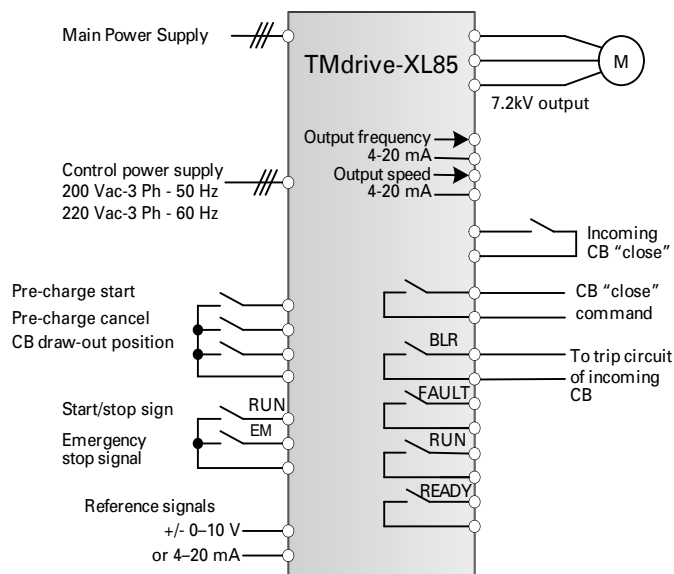

Control Area	Specifications
Analog Inputs	(2) ± 10 V or 4-20 mA, configurable, differential, 12-bit Sampling time 1 ms
Analog Outputs	(4) ± 10 V or 8-bit, configurable, 10 mA max, 12-bit Sampling time 1 ms
Digital Inputs	(2) 24-110 V or 48-120 V ac; (6) 24 V dc, configurable
Digital Outputs	(6) 24 V dc open collector 50 mA
Speed Feedback Resolver Input	Not provided as standard
LAN Interface Options	Profibus-DP, ISBus, DeviceNet™, TC net, or Modbus RTU
Motor Temperature Sensor	High-resolution motor temperature feedback: 1 k Ohm platinum resistor or 100 Ohm platinum RTD (uses analog input with signal conditioner)

Specifications

Converter type

- AC-fed multi-pulse diode using phase shifted transformer
- DC bus voltage: 3 x 5450 Vdc

Transformer

- Oil immersed type transformer
- Air cooled type
- Multi windings

Inverter

- Five-level inverter for motor friendly wave form
- Motor voltage: 7200 V
- Rated frequency: 50/60Hz
- 200Hz, maximum frequency
- Minimum rated frequency 50Hz

Applicable Standards

- IEC61800-4, JIS, JEC, JEM, CE (option), CSA (option)
- IEC 60146-1, 18.5 kV for 1 minute withstand

Control

- Nonvolatile memory for parameters and fault data
- Volt/Hertz control
- Sensorless vector (option)

Protective Functions include:

- Inverter overcurrent, overvoltage
- Low or loss of system voltage
- Motor ground fault
- Motor overload
- Cooling fan abnormal
- Over-temperature
- CPU error
- Water cooling unit alarm
- Exciter fault
- DC voltage drop
- Motor inverse rotation
- Stall detection
- Ground detection

Enclosure

- IP42 except for tan openings (IEC 60529), NEMA 1 gasketed equivalent
- Color: Munsell 5Y7/1 (Option: ANSI 61 gray, RAL7032 etc.)

Cable Entrance

- Top access standard
- Bottom access – consult factory

Air Filters

- Air filters on front and rear doors can be replaced with door closed

Sound

- Average is below 80 dBA one meter from cabinet

Cooling Water Conditioning Equipment

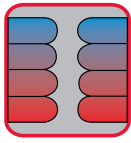

Water conditioning control panel continuously monitors the status of the water system. Separate fault indications help find and fix problems fast. Operator panel shown on page 15.

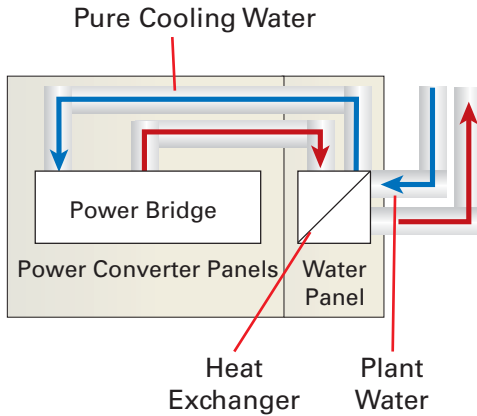

Water conditioning system behind Gate Drive Panel

Water to water heat exchanger keeps the de-ionized system isolated from the plant water supply.

Surge tank absorbs water during pump transients and indicates the internal cooling loop water level.

De-ionizer removes contaminants from the internal cooling loop.

Redundant pumps keep the system running even if one pump fails

Cooling Equipment Panel

Type	Heat Exchange Capacity kW	Width mm (in)	Depth mm (in)	Height mm (in)	Weight kg (lbs)	Power Supply kVA	Notes
Single Bank Drive	410	1100 (44)	1800 (71)	2614 (103)	2300 (5060)	24	Capacity for one bank. Plant water required: 1100 l/min (297 gal/min)

Inlet Cooling Water Temperature Requirements & Power Derating

Cooling Water	Maximum Water Temperature °C (°F)
	One Bank
Cooling water supplied by plant (Industrial water)	40 (104)
Cooling, de-ionized water flowing through the power unit (Pure water)	47 (116)
Cooling, de-ionized water flowing through the power unit (Pure water) - Alarm temp.	48 (118)
Cooling, de-ionized water flowing through the power unit (Pure water) - Fault temp.	50 (122)

Industrial Water Temperature at the Cooler Inlet	
Temperature °C (°F)	Drive Output Current Derating Factor
32 (90)	1.00
40 (104)	1.00
45 (113)	0.90

Operator Interfaces

Standard Display

Compact Control Panel (Single Bank or Two Banks)

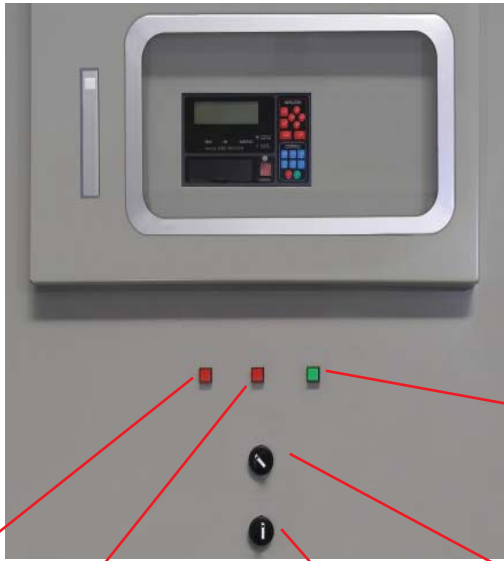

Fault Lamp AC On Lamp Pre-charge Switch Local/Remote Switch AC Off Lamp

Interface and Water Cooling Panel



De-ionized Water Quality Monitor

Indicator Lights and Labels

Keypad

High Function Display

- LCD backlight gives great visibility and long life
- Bar graphs, icons, menus, and digital values combine to provide concise status information, often eliminating the need for traditional analog meters



Easy-to-understand navigation buttons allow quick access to information without resorting to a PC-based tool

Switch to local mode and operate the equipment right from the keypad

RJ-45 Ethernet port is used for the local toolbox connection

Instrumentation Interface

- Two analog outputs are dedicated to motor current feedback
- Five analog outputs can be mapped to variables for external data logging and analysis

Interlock button disables the drive

TMdrive-XL85 Drive and Motor Test Facility – 30 MVA

Back-to-Back Tests

The TMdrive-XL85 has been thoroughly tested under full load conditions in TMEIC's new test facility shown below. For the 25 MW back-to-back tests, TMEIC designed a 25 MW synchronous two-pole motor for 3600 rpm operation and a 25 MW synchronous four-pole generator for 1800 rpm operation. Power from the generator is sent to four regenerative TMdrive-70 drives which regenerate 25 MW to drive isolation transformers. The output of these transformers match the 11 kV main power grid.

With this test stand, full load and speed can be applied to the drive and motor while the total test power requirements only need to make up power for the electrical losses. The drive's new five-level inverter topology and sophisticated Pulse Width Modulation control can be fully tested.

25 MW TMdrive-XL85 five-level GCT drive to power the motor

Regenerative TMdrive-70 three-level IEGT drive to recirculate power back to the supply



Drive Test Data

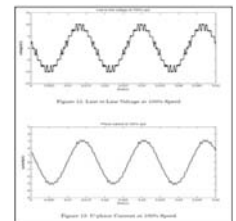

Drive output voltage and current at full speed

Drive Power MW



Motor Speed RPM

Center display: drive output volts to motor

25 MW synchronous 2-pole variable speed motor, 3600 rpm

Gearbox, 2:1 ratio

Synchronous 4-pole generator

The results of these tests demonstrate the suitability of electric drive systems for large compressor applications. Desirable features are proven, such as a clean output waveform at full speed and generation of very little output torque ripple.

TMEIC Drives Offer Complete Coverage

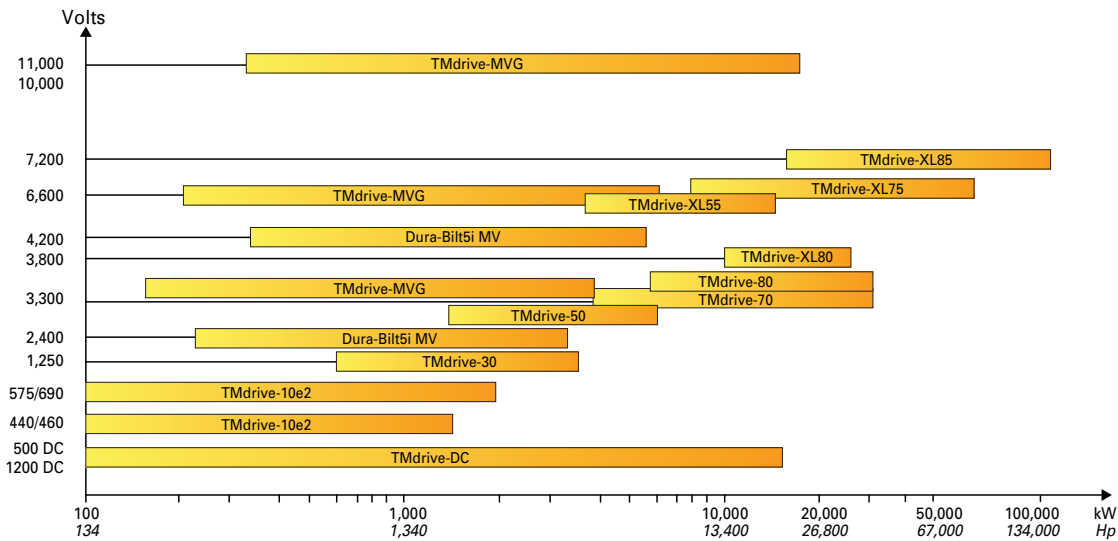

Global Office Locations:

TOSHIBA MITSUBISHI-ELECTRIC INDUSTRIAL SYSTEMS CORPORATION

Mita 43 MT Bldg.
13-16 Mita 3 chome, Minato-ku Tokyo
108-0073 Japan
Tel.: +81-3-5441-9788
Fax: +81-3-5441-9795
Web: www.tmeic.com

Shanghai TMEIC Electric Drive Technology Co.

Rm 2901, Shanghaimart, 2299 Yan'An Rd. (W),
Changning Districk, Shangai 200336, P.R. China
Tel.: +86-21-6236-0588 ex 717
Fax: +86-21-6441-3019

TMEIC Asia Company Limited

152 Beach Road #16-00 Gateway East, Singapore 189721
Tel.: +65-6292-7226
Fax: +65-6292-0817

TMEIC Corporation

Office: 1325 Electric Road, Suite 200
Roanoke, VA, United States 24018
Mailing: 2060 Cook Drive
Salem, VA, United States 24153
Tel.: +1-540-283-2000
Fax: +1-540-283-2001
Email: GI@tmeic.com
Web: www.tmeic.com

TMEIC Houston

2901 Wilcrest Drive, Suite 110
Houston, TX, United States 77042
Email: OilGas@tmeic.com
Web: www.tmeic.com

TMEIC Europe Limited

6-9 Stockley Park
Uxbridge, Middlesex, UB11 1FW United Kingdom
Tel.: +44 870 950 7220
Fax: +44 870 950 7221
Email: info@tmeic-eu.com
Web: www.tmeic.com

TMEIC Industrial Systems India Private Limited

Unit 03-04, Third Floor,
Block 2, Cyber Pearl, HITEC City, Madhapur,
Hyderabad, 500081, Andhra Pradesh, India
Tel.: +91-40-4434-0000
Fax: +91-40-4434-0034
Email: inquiry_india@tmeic.com
Web: www.tmeic.in

TOSHIBA MITSUBISHI-ELECTRIC INDUSTRIAL SYSTEMS (BEIJING) CORP.

21/F, Building B, In.do Mansion
48 Zhichunlu A, Haidian District,
Beijing 100098, PRC
Tel.: +86 10 5873-2277
Fax: +86 10 5873-2208
Email: sales@tmeic-cn.com

TMdrive is a registered trademark of TOSHIBA MITSUBISHI-ELECTRIC INDUSTRIAL SYSTEMS CORPORATION.

All other products mentioned are registered trademarks and/or trademarks of their respective companies.

All specifications in this document are subject to change without notice. The above brochure is provided free of charge and without obligation to the reader or to TMEIC, and is for informational purposes only. TMEIC does not accept, nor imply, the acceptance of any liability with regard to the use of the information provided. TMEIC provides the information included herein as is and without warranty of any kind, express or implied, including but not limited to any implied statutory warranty of merchantability or fitness for particular purposes. The brochure is not an implied or express contract.